

new

T96 AND T98NR® RACK AND PINION TILT STEERING SYSTEMS

A COMPLETE STEERING SYSTEM CONSISTS OF:

- Preassembled helm with steering cable:
TM86
- Helm assembly:
G96 - 39650 L standard
G98NR® - 39649 C non reversible
- Tilt mechanism:
X52 - 39250 U
NOTE: X52 Tilt mechanism fits also Ultraflex tilt mount rotary steering systems (page 13) and Ultraflex hydraulic steering pumps UP28T, UP33T and UP39T (page 55)
- Optional steering wheel (see index)
- Engine connection kits (see index)

FEATURES AND TECHNICAL SPECIFICATIONS:

- Easy and safe steering: the patented non reversible G98NR helm eliminates the continuous load on the operator caused by the propeller torque
- Fast, simple installation
- Tilt range of 48° and five locking positions
- Tilt device eliminates underdash movement
- Standard 3/4" tapered shaft.
- All stainless steel cable output ends
- Made exclusively in corrosion resistant materials.
- Lock-to-lock steering wheel turns: 3,5
- Stroke: 8.2" (210 mm)
- Maximum allowable steering wheel diameter: 16.5" (420 mm)
- Minimum steering cable bend radius: 7.9" (200 mm)
- T96 and T98NR® steering systems are not to be used on boats equipped with engines that exceed the maximum horsepower rating of the boat
- Exceeds EN 28848 safety standards
- Exceeds ABYC P17 safety standards

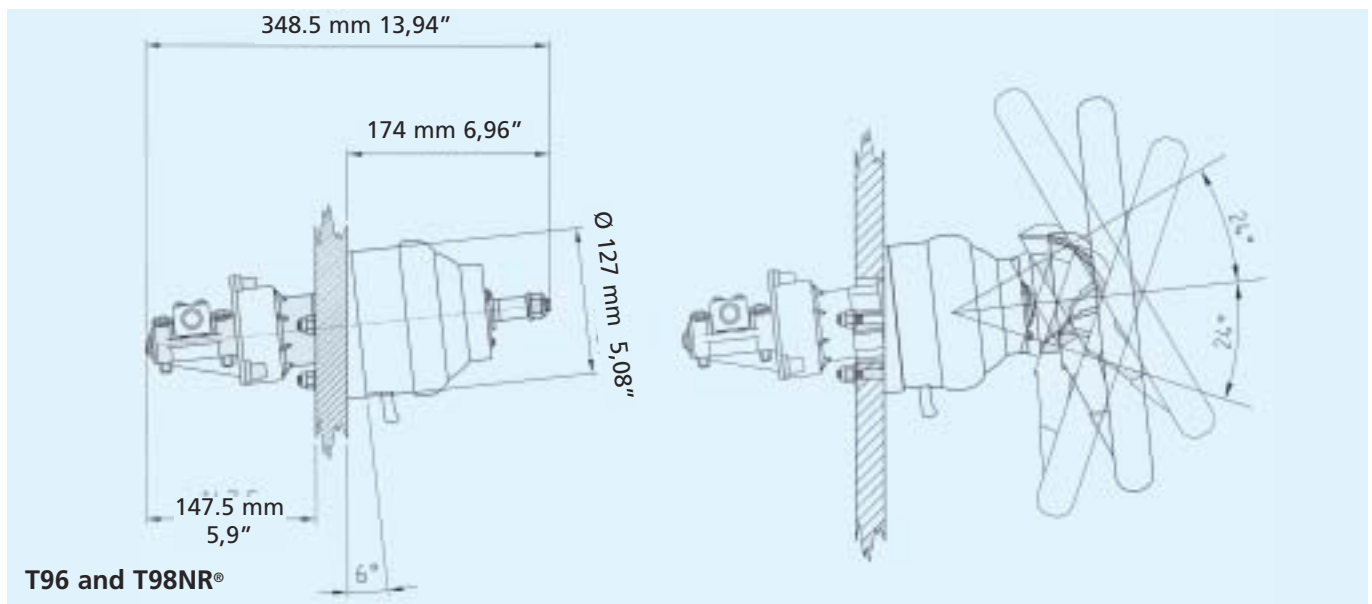

15